

Specification

1. Input Voltage: AC220-240V 50/60Hz
2. Wattage: 1W
3. Power factor:0.83PF, supply current:11mA
4. Lumens: 120lm.
5. Battery installed or replaced: LiFeP04 3Ah.
6. Operating environmental temp: 0° to +40°C.
7. Recharge time: 24 hours.
8. Emergency duration: more than 3 hours.

Important Information

We recommend that luminaires are installed by a qualified electrician ensuring the installation complies with current IEE wiring regulations BS7671:2018 & local building control.

- All tests should be carried out in accordance to EN 50172:2004.
- BELL will not accept responsibility for any claims arising from a poor installation.
- The light source of this luminaire is not replaceable: when the light source reaches end of life, the whole luminaire must be replaced.

Important User Advice

- The ambient room temperature should not exceed 30°C.
- Ensure that there is adequate free air ventilation around the fitting.
- Always switch off mains supply before installing.

This product may contain substances that can be hazardous to the environment if not disposed of properly. Electrical and electronic equipment should never be disposed of with general household waste but must be separated for its correct treatment and recovery.

Where possible recycle your packaging.  

Read these instructions before installation and retain for future reference 

This equipment should be installed by a competent electrician

Dimensions

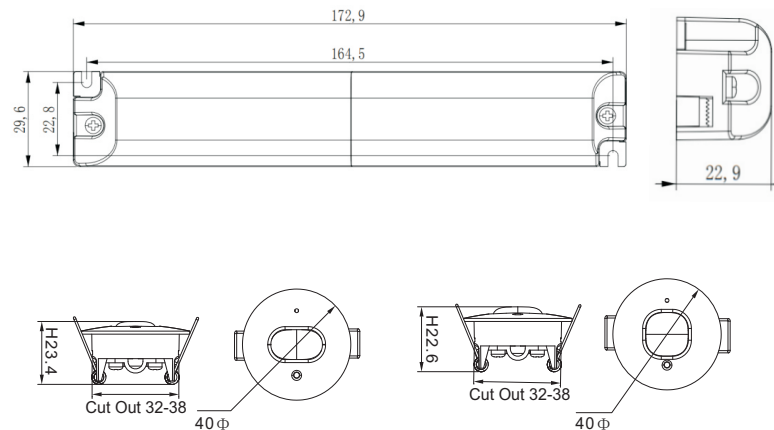

Wiring Diagram

